

# AFM-460B Fully Automatic case making machine

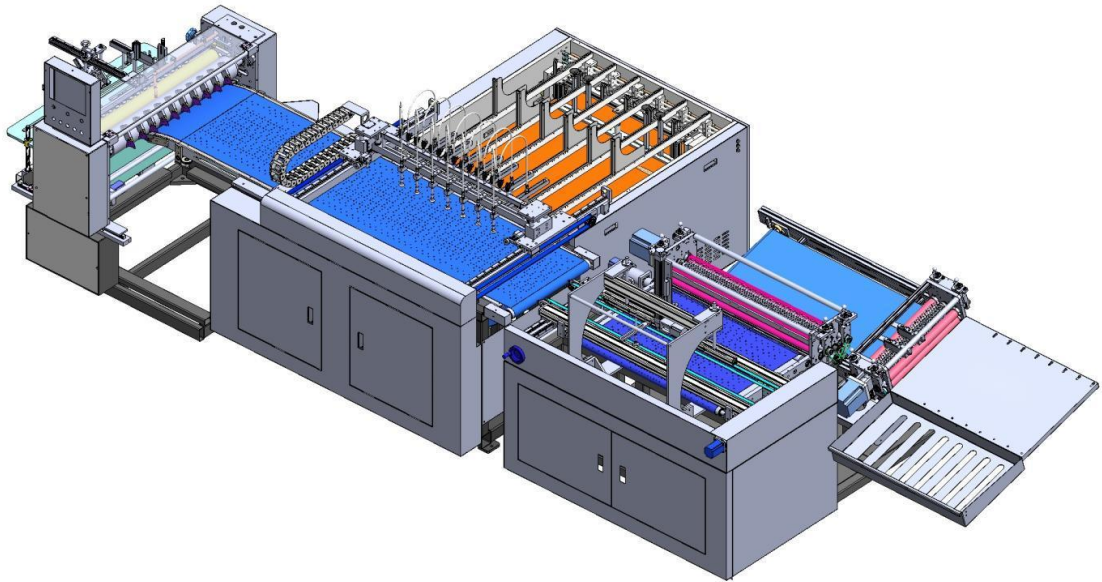

This is new model on basic of old case maker machine structure and much experience on case maker technology in China, and this new model machine with double correction side and positioning the board onto the paper, it is improved the speed and precision.

## Technical Parameters:

Minimum Size(Open case)	L:190mm W:170mm
Maximum size(Open case)	L:900mm W:460
Minimum thickness of the board	1.5mm
Maximum thickness of the board	6.0mm(Possibility to work different board thickness on the same cover)
Overlap covering material	15mm~30mm
Cover material types	Textile,laminated paper,photo paper,imitation-leather,PVC polyurethane
Cover material thickness	80~350g/m2
Glue tank capacity	20kg
Glue type	Hot animal glue, cold glue for lining works only
Productivity	25-30pcs/min
Overall dimensions	Length:5500mm,Width:5000mm
Electrical Power	380V 3Phases+G+N 50/60Hz
Timer for glue heating	To programme the switching ON/OFF of the glue heating
Power	12KW
Compressed Air	5.0Bar
Viscosimeter	Automatic control the glue viscosity by computer setting,complete of glue mixer,glue level sensor and automatic,Water feeding to keep the glue viscosity
Finished product collecting table	950mm x 460mm

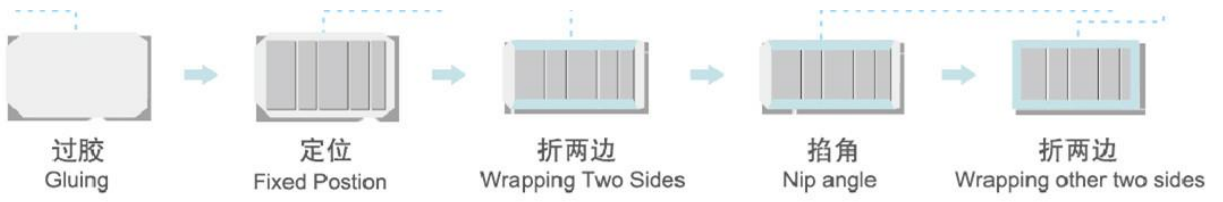
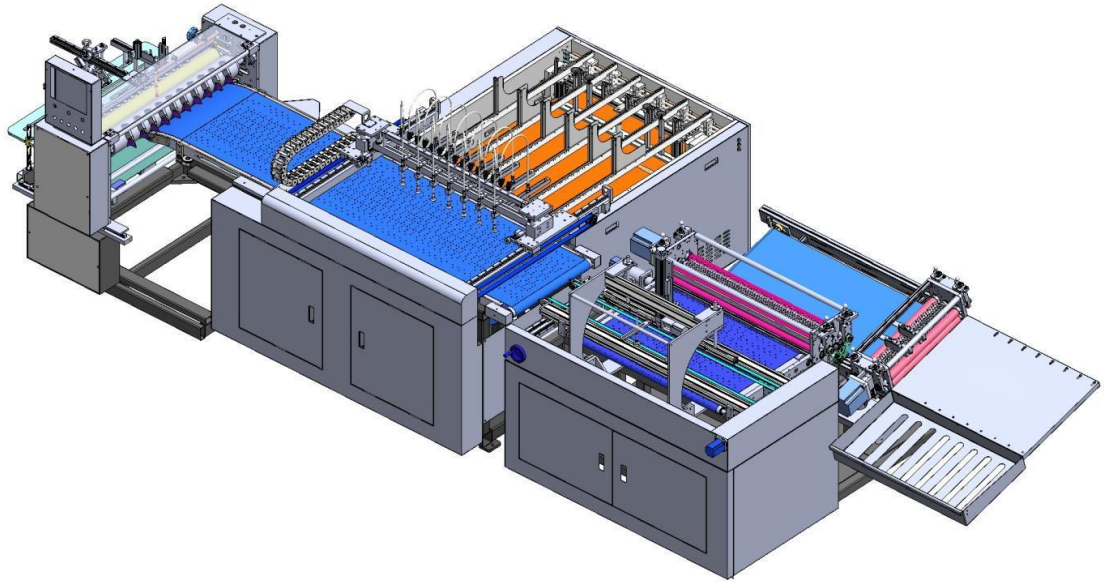

Sample:

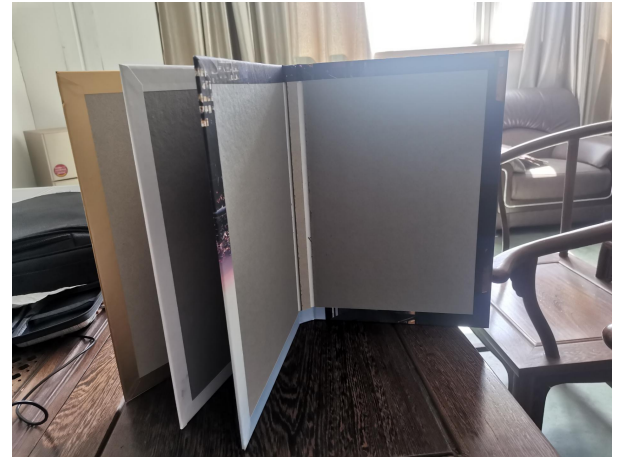
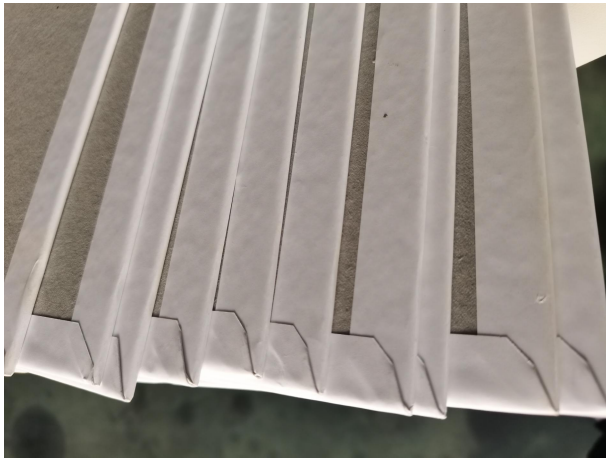
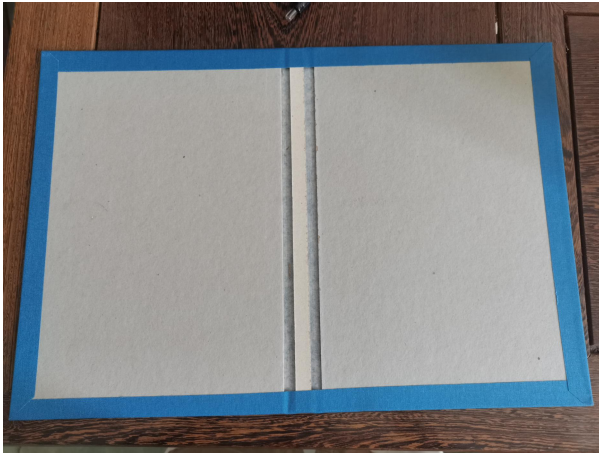

Workshop: